



EXTRACTOR HIDRÁULICO DE 15 TON 1315TH **15 TONS HYDRAULIC PULLER serie 1315TH**



Manual de instrucciones *Manual instructions*



ES

MI1315TH
Rev. 2 - 22.02.2024

Contacto: ventas@forza.es / www.forza.es



EN

Cracterísticas técnicas / Characteristics

Extractor hidráulico de 15 Toneladas de 3 patas. / 15Tn hydraulic 3 jaws puller.
 Patas normales (2 agujeros), patas largas L (3 agujeros), patas extralargas X (4 agujeros).
 / Standard jaws (2 holes), long jaws L (3 holes) and extra long jaws X (4 holes)

- Sistema hidráulico: extracción más rápida con menos esfuerzo. / Hydraulic mechanism: faster pulling with less effort.
- Más rigidez en la extracción: la fuerza se aplica directamente sobre el cuerpo. / The force is applied directly to the body
- Pasador de seguridad para no sobrecargar el husillo. / Safety pin to avoid overloading the spindle.
- Mejora la extracción al tener tres puntos de apoyo. / Safety pin to avoid overloading the spindle.

Ref.	A	B	F	TON	Peso	Pata
1315TH	265	425	101683	15	20,0	131750
1315LTH	370	480			23,0	131750
1315XTH	500	540			26,0	131760

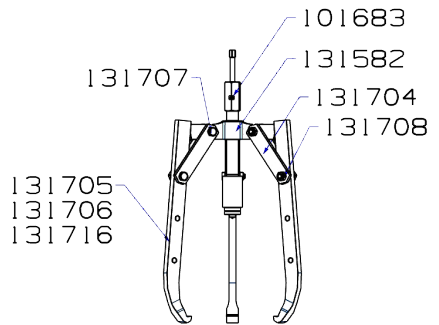
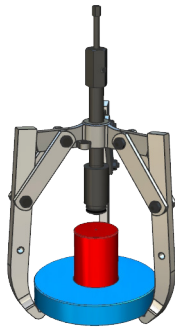
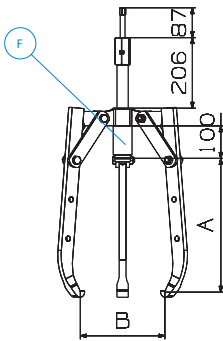

Husillo 15 ton / 15 tons spindle

El subhusillo se debe apretar con una llave fija del 17. / *The subspindle shall be tighten with a spanner of 17.*

Con dicha llave llegará fácilmente a las 15 toneladas. / *By using this spanner 15 ton are easily reached.*

Nunca utilice tubos ni palancas para hacer más fuerza. / *Never use neither pipes nor levers to apply more force.*

Husillo ref. 101683

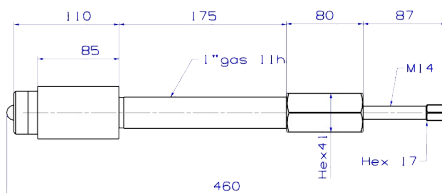

Instrucciones de uso / Use instructions



1- Suelte el prisionero M-8 con una llave. / *Release the M-8 prisoner with a key.*



2- Desenrosque la cabeza del husillo. / *Unscrew the spindle head.*

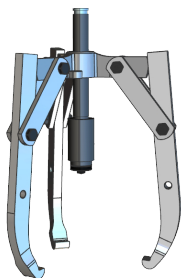

3- Rosque el husillo al cuerpo / *Thread the spindle to the body*

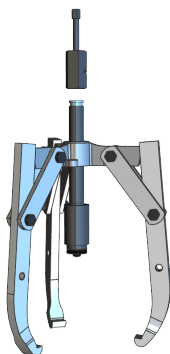

4- Rosque la cabeza al husillo. / *Thread the head to the spindle.*

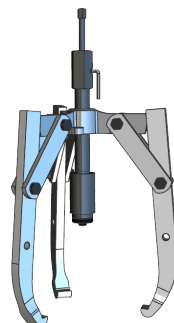

5- Apriete el prisionero M-8. / *Tighten the M-8 prisoner.*

Instrucciones generales / *General instructions*



**NO ES RECOMENDABLE USAR
LLAVES DE IMPACTO / IT IS
NOT RECOMMENDED TO USE
POWER TOOLS**

- 1- Engrase los husillos. / *Make sure the spindle is cleaned and greased before use.*
- 2- Compruebe que el eje esta punteado, si no utilice un protector de punto. / *Make sure the axle has a centre hole. If not use a point protector.*
- 3- Asegúrese de que las patas o alargaderas estén perfectamente centradas. / *Make sure the jaws are evenly spread*
- 4- Realice la fuerza girando el husillo, NO golpee el husillo. / *Apply pulling force by turning the spindle. Never hit the spindle and not use power impact wrench.*
- 5- Mantenga las normas de higiene y seguridad en el trabajo. / *Keep the standards of hygiene and safety at work.*
- 6- Utilice los elementos de protección individual obligatorios. / *Always wear suitable personal protective equipment.*

